

ITEM NO.	QTY.	PART NO.	DESCRIPTION	FRAME COLOR
1	3	7637901	ASSY, ROLLER-CONCAVE	-
2	1	8327901	ASSY, CM/MJ PULL PIN, BEVEL NOSE	-
3	1	7351501	SPRING, PULL PIN LARGE	-
4	1	7351401	KNOB, TULIP STYLE	-
		7424803	KNOB, POP PIN, YELLOW	
5	1	7645401	SHAFT, CM/MJ, 6203 BRNG	-
6	2	3245901	BEARING, 6203	-
7	2	3232413	RING, BRE .631, 5100-66, ST PP B	-
8	12	3236601	WASHER, 3/8 SAE SS	-
9	1	3236217	SCREW, M10 X1.5 100MM	-
10	6	3236801	NUT, M10 HEX NYLOCK SS	-
11	4	3239101	SCREW, M5X10 PHL PAN TT ST	-
12	1	3237801	PULLEY, 4.5" OD	-
13	1	3245701	PULLEY, 3.5" OD, 10MM ID SG	-
14	3	3236216	SCREW, M10 X1.5 95MM	-
15	2	3236206	SCREW, M10 X1.5 45MM	-
16	1	8039501	LABEL, WARNING, TRIANGLE	-
17	1	7821001	LABEL, WARNING ADJ. CARRIAGE	-
18	1	8346901	WLDMT, CMDAP RH CARRIAGE	ANY
19	1	7633301	WLDMT, CM/MJ, SWIVEL PULLEY	ANY
20	1	7631801	BRKT, CM/MJ, CARRIAGE SHROUD	ANY

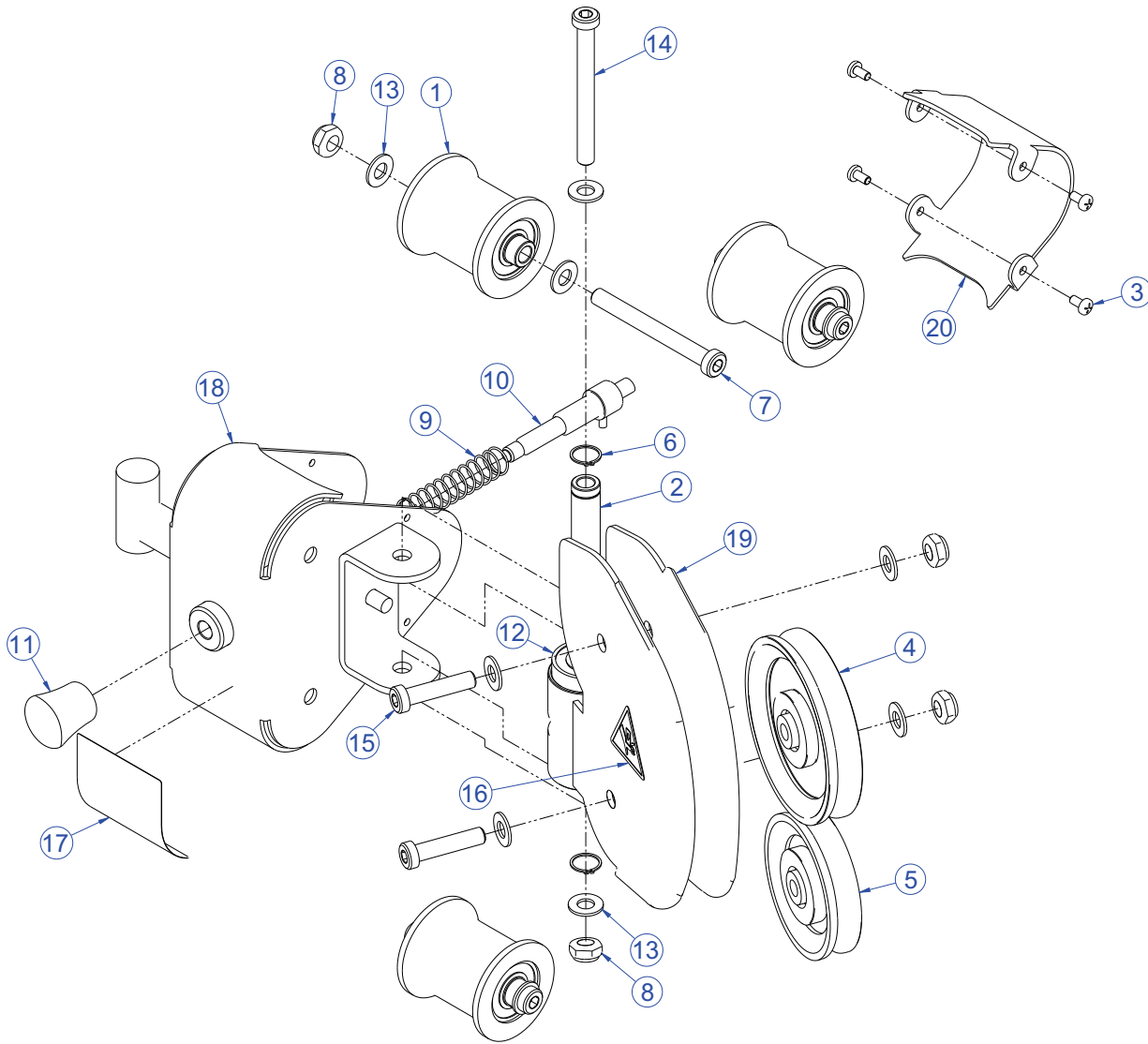

ITEM NO.	QTY.	PART NO.	DESCRIPTION	FRAME COLOR
1	3	7637901	ASSY, ROLLER-CONCAVE	-
2	1	7645401	SHAFT, CM/MJ, 6203 BRNG	-
3	4	3239101	SCREW, M5X10 PHL PAN TT ST	-
4	1	3237801	PULLEY, 4.5" OD	-
5	1	3245701	PULLEY, 3.5" OD, 10MM ID SG	-
6	2	3232413	RING, BRE .631, 5100-66, ST PP B	-
7	3	3236216	SCREW, M10 X1.5 95MM	-
8	6	3236801	NUT, M10 HEX NYLOCK SS	-
9	1	7351501	SPRING, PULL PIN LARGE	-
10	1	8327901	ASSY, CM/MJ PULL PIN, BEVEL NOSE	-
11	1	7351401	KNOB, TULIP STYLE	-
		7424803	KNOB, POP PIN, YELLOW	
12	2	3245901	BEARING, 6203	-
13	12	3236601	WASHER, 3/8 SAE SS	-
14	1	3236217	SCREW, M10 X1.5 100MM	-
15	2	3236206	SCREW, M10 X1.5 45MM	-
16	1	8039501	LABEL, WARNING, TRIANGLE	-
17	1	7821001	LABEL, WARNING ADJ. CARRIAGE	-
18	1	8346701	WLDMT, CMDAP LH CARRIAGE	ANY
19	1	7633301	WLDMT, CM/MJ, SWIVEL PULLEY	ANY
20	1	7631801	BRKT, CM/MJ, CARRIAGE SHROUD	ANY